

Pressure always under control.

Rev. 0 – 10/2017

AUTOMATIC FILLING UNITO FOR HEATING SYSTEMS

371078 134



Direct acting automatic filling unit made in brass

PN 16 – Max inlet pressure 16 bar

Outlet pressure range 0,5 bar – 4 bar

Factory setting 1,5 bar

Maximum working temperature: 80° C

Brass diaphragm

Built in strainer

Built in isolating galve

Built in check valve valve

Pressure gauge connections ¼"

Threaded FF ISO 228

Available sizes 1/2" (DN15)

External sand blasted brass or nickel plated

EAC

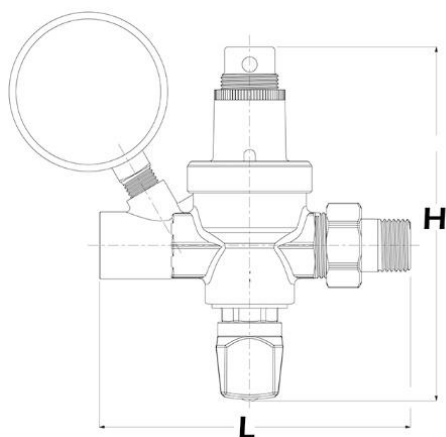

Item N	Size	DN	H mm	L mm	Weight Gr
111R	1/2"	15	140	122	770

Pressure always under control.

INSTALLATION GUIDELINES

The automatic filling unit is suitable in water supply pipe work for heating systems; consisting in a pressure reducer valve with shut off valve and check valve, maintains a stable pressure in the whole heating system and, when needed, automatically feeds water into the system.

For better functioning of the heating system, outlet pressure should never exceed 2 bar (30 psi). Once the setting pressure into the heating system is reached, the filling unit automatically shut off; operating on the shut off valve, by turning black plastic handle counter-clockwise, feed can be stopped manually.

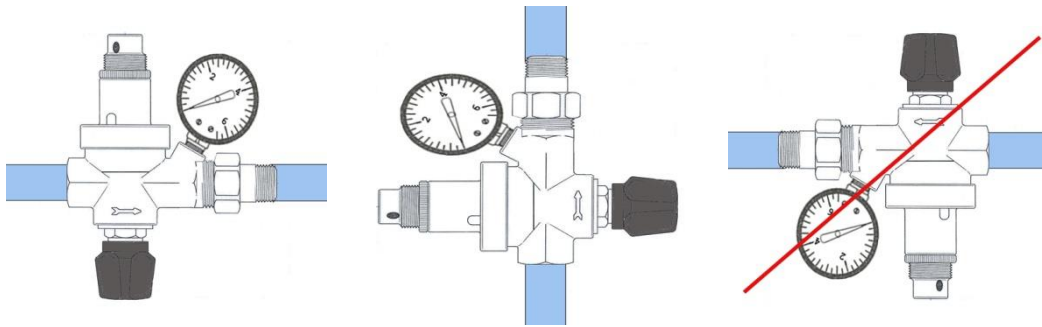

The automatic filling units don't get the effects – for their functioning – of the gravity force; even if they can be installed in the plant in any position, we suggest not to install them up-side-down:

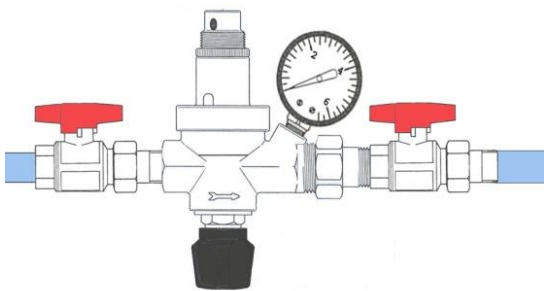

For quick installation and fast service, if requires, we recommend to install isolating valves upstream and downstream the valve.



All filling units are tested before being packaged; during the proof they are pre-set at the outlet pressure of 1.5 bars; the outlet pressure can be easily modified when the valve is installed on the plant.

We always suggest the use filling valve with outlet pressure lower than 2 bar for a better functioning of the heating system.

In order to modify the outlet pressure, loosen the black plastic fixing ring and turn the spring holder as indicated in the pictures sequence. By turning clockwise the outlet pressure increases, while counter-clockwise the pressure decreases. A right setting should be made while the plant outlet is closed.

⚡WARNING: Installation or any change of outlet pressure must be performed by qualified personnel.